

Elster® enCore FC1

High performance flow computer

Applications

The Elster enCore FC1 is a modular oil and gas flow computer based on future-proof hardware and software concepts

Brief information

The Honeywell Elster FC1 flow computer is designed for gas and/or liquid measurement applications and the corresponding calculation algorithms. Multi-stream functionality and advanced logging properties with a wide range of security and communication features are available. enCore, which means Honeywell Elster new Core, is the 'base plate' of the FC1. This backbone of the new flow computer contains the basic functionalities. A modular software system consisting of independent application function blocks (AFBs) turns the FC1 into a reliable, secure and high performance flow computer.

By using cryptographic mechanisms, it can be securely updated and upgraded even in a fiscal way. Since this scalable software system is also modular in terms of hardware, the widest range of applications is possible. Two different housing sizes can effectively accommodate the required number of I/O boards, so no space is wasted. In combination with input boards with integrated Ex-barriers, small stations will also be able to be equipped with a high-end flow computer.

The widest range of calculation algorithms pursuant to AGA, ISO and API are implemented to fulfill all requested flow conversion requirements. The user-definable logging feature can use any desired amount of flash memory, thus causing no more restrictions in logging depth. Multiple-user functionality and complex audit trails simplify the security management and enable service staff to retrieve the history of the unit whenever it is required.

The PC software is available in two different configuration modes which combine ease of use with the full flexibility of this highly complex flow computer. The 'Normal mode' is intended for standard applications and is optimized for fast configuration. The 'Expert mode' allows all technical possibilities to be exploited. To allow connection to a wide range of electronic measurement devices such as analyzers, ultrasonic meters and transmitters the enCore FC1 features predefined device drivers. For the most common devices, predefined communications procedures are available.



FEATURES & BENEFITS

Main Features

- Modular hardware architecture (one interface board per stream)
- Partial software upgrade/update via USB or TCP/IP
- Enhanced data logging functionality
- Calculations according to AGA/ISO/API/GPA
- Ethernet: HTTP/MMS/Modbus/NTP protocols
- USB front panel interface
- Configurable layout of user-defined displays
- Multiple language system (selectable online)
- Optionally integrated intrinsically Ex-barriers
- Low power consumption
- Liquid measurement
- PID control
- Turbine Lubrication
- Soft PLC
- Printer support

Hardware

The board configuration of the enCore FC1 is modular. The housing can be supplied either in 1/3 design width of 19", or in 1/2 design width of 19". The main difference between the two is the possible number of input, output and communications boards (1/3 design width = 4 board slots; 1/2 design width = 7 board slots).

CPU board

The CPU contains the following connections:

- LAN network connector
- Serial channel
- Serial channel
- Power supply 24V

MFE7 input board

The MFE7 provides a total of 7 multi-functional inputs:

- 4-channel PT100 input for connecting an analogue temperature sensor
- 4-20 mA analogue input or HART input with up to 4 transmitters (multi-variable and burst mode possible)
- Digital input for HF, LF, encoders or status
- Digital input for HF, LF or status
- Digital input for HF, LF or status
- RS485 serial channel

Before using the MFE7 input board, it must be

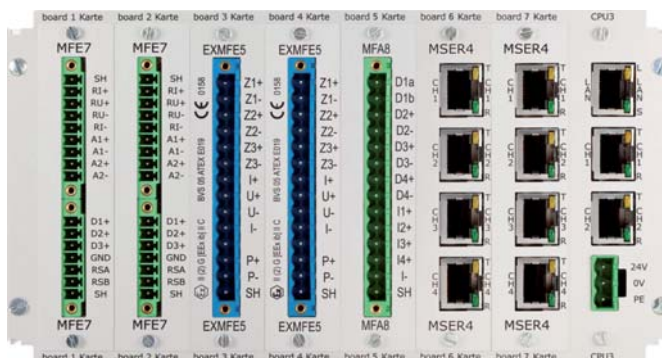

ensured that the required Ex-barriers are fitted in the control cabinet. They are not needed when using Ex-d sensors instead. In addition, the MFE7 can ensure the voltage supply to both current inputs and thus reduce the amount of wiring required. The HF inputs can be configured to work with pulse integrity checking according to ISO 6551 Level A.

ExMFE5 input board

The ExMFE5 provides a total of 5 multifunctional inputs and an integrated ATEX-compliant isolating amplifier:

- Digital input for HF, LF, encoders or status
- Digital input for HF, LF or status
- Digital input for HF, LF or status
- 4-channel PT100 input for connecting an analogue temperature sensor
- 4 – 20mA analogue input or HART input with up to

4 transmitters (multi-variable and burst mode possible)

The ExMFE5 allows very compact wiring to be achieved in the measuring system. All the sensor inputs can be connected directly without intermediate wiring. No isolating amplifiers or supply voltage must be connected to the inputs.

MFA8 output board

This output board provides 8 multi-functional outputs.

- LF or status digital output (normally closed)
- LF or status digital output (Normally Open)
- LF or status digital output (Normally Open)
- LF or status digital output (Normally Open)
- 0/4 – 20 mA analogue output
- 0/4 – 20 mA analogue output
- 0/4 – 20 mA analogue output
- 0/4 – 20 mA analogue output

ESER4 serial communications board

The ESER4 provides 3 serial channels and 1 Ethernet port. All 3 serial channels can be configured flexibly for a wide range of protocols. Baud rates of up to 38 kBaud can be supported.

AFBs (Application Function Blocks)

The list of available AFBs is continuously growing. The following provides a current snapshot:

Gas Flow Conversion and Gas Quality

The combination of the Flow Conversion and Gas Quality AFBs forms a complete volume conversion system for one stream. The usual conversion variants to AGA 8, SGERG-88, AGA NX-19, etc. are implemented. The conversion factor C is formed from the gas composition, measuring pressure and measuring temperature. Together with the calculation according to ISO 6976 or GPA 2172, the calorific value, density, Wobbe index and other intermediate values can be calculated. The theoretical VOS calculation to AGA 10 can also be carried out. In the Flow Conversion AFB, the values from the Gas Quality AFB and the flow rate of the meter are used to generate the various meter values such as operating volume, standard volume, energy and mass. Using the meter correction curve, the known inaccuracies of the meter can then be compensated for in the flow computer.

Post Processing

All internal measurements, meter readings and events can be processed in this AFB. This makes it possible, for example, to complete simple combination tasks using AND or OR. Measurements and meter readings can be processed by a wide-ranging function library using various standard methods. Currently, this AFB provides the following variants: arithmetic mean, weighted mean, min.-max. value

formation, timebased instantaneous values (e.g. hourly meter readings) and consumption values (consumption over the last hours).

Archives

Up to 900 values can be recorded at a time in this AFB. The cycle is user-configurable and the composition of the values is also variable. The archived data can be read using enSuite and Modbus.

Station

The Station AFB can take on higher level tasks. For example, it can create station totals for the main meter indexes for multistream applications. The accuracy of a permanent series configuration of two meters can also be checked continuously or after manual activation. In a velocity of sound comparison (VOS), a permanent verification routine to compare the measured VOS of the ultrasonic meter and the theoretical VOS calculated pursuant to AGA 10 in the Gas Quality AFB runs in the background.

Modbus

The Modbus AFB can be used to forward all the available values from the enCore FC1 to connected systems. At the same time, values can be read into the FC1 and it is possible then to use these values for calculations, archive them or simply display them. The special feature which should be mentioned is that in the known operating modes to RTU, ASCII and TCP, this AFB is not only able to act as a slave/server but also as a master/client. In master/client mode, connections can be made to up to 10 communications partners and their data retrieved or recorded. This means that any enCore FC1 can also be used as a fully flexible Modbus gateway.

Liquid Flow Conversion / Liquid Quality

The combination of Liquid Flow Conversion and Liquid Quality forms the application for liquid conversion. The liquid tables and standards for crude oil, water, lighter hydrocarbon liquids, LPG, refined products and lubrication oils are available.

enCore FC1				CPU3 board	MFE7 input board	ExMFE5 input board	MFA8 output board	SER4 comm. board
SAP code	Operating mode	streams	Intrinsically safe inputs	FC 8100001	FC-MFE7	FC EXMFE5	FCO-MFA8	FC ESER4
FC1	Turbine	1	x	1	-	1	1	-
	Turbine	2	x	1	-	2	1	-
	Turbine	3	x	1	-	3	1	-
	Turbine	4	x	1	-	4	1	-
	Ultrasonic	1	x	1	-	1	1	-
	Ultrasonic	2	x	1	-	2	1	1
	Ultrasonic	3	x	1	-	3	1	1
	Ultrasonic	4	x	1	-	4	1	1
	Orifice	1	x	1	-	2	1	-
	Orifice	2	x	1	-	4	1	-
	Turbine	1		1	1	-	1	-
	Turbine	2		1	2	-	1	-
	Turbine	3		1	3	-	1	-
	Turbine	4		1	4	-	1	-
	Ultrasonic	1		1	1	-	1	-
	Ultrasonic	2		1	2	-	1	-
	Ultrasonic	3		1	3	-	1	-
	Ultrasonic	4		1	4	-	1	-
	Orifice	1		1	-	2	1	-
	Orifice	2		1	-	4	1	-

enCore FC1 basic operating modes

The following table shows the different basic operating modes of the enCore FC1 with the corresponding standard board configuration. Other boards can be added optionally during the order process. In addition, the device can also be ordered without a basic operating mode to allow for the creation of mixed setups.

enCore FC1 Technical Specifications

Technical Data	
Calculations: gas	Compressibility: SGERG, AGA-NX19, AGA Report No. 8 (full gas composition), constant k-factor, heating value & relative density: ISO 6976 (mass or volume based). Gas quality values: ISO 6976, GPA 2172, AGA Report No 10 VOS comparison Orifice calculations: AGA 3, ISO 5167
Calculations: liquids	GPA-TP27 table 59E/60E, API 12.2.5.3 table 54, API 11.2.1, API 11.2.2, Table 53A/54A, Table 53B/54B and Table 53D/54D as listed in "API MPMS 11.1 Temperature and Pressure Volume Correction Factors for Generalized Crude Oils, Refined Products and Lubricating Oils (2004)" Table 53A/54A, Table 53B/54B and Table 53D/54D as listed in "API MPMS 11.1 VOL X Volume Correction Factors (1980)" Table 53/54 as listed in ASTM-IP Petroleum Measurement Tables, (ASTM D 1250; IP 200) First Edition 1952
Densitometer algorithms	Solartron/Micro Motion
Data logging	Measurement archives API21.1; fully flexible data logging structure with a large database size
Data communication	1 USB interface on the front panel for parameterization and servicing purposes 1TCP/IP interface on the CPU board. Up to 16 serial interfaces (depending on board configuration)
Printer	Network and serial printer support
Ethernet communication	NTP, Modbus TCP, MMS (Manufacturing Message Specification to ISO 9506), HTTP
Serial communication	Modbus (ASCII, RTU), Uniform, Encoder, Printer
CPU3 board	- Ethernet connector (LAN) - 2 x serial connector (RS232, RS485, RS422) - 24 V power input
Input boards	
EXMFE5	- 3 pulse or signal inputs (NAMUR), [EEx ib] IIC, one of which alternatively suitable for an ENCODER index - Process input for sensors with 4 – 20 mA interface [EEx ib] IIC, alternatively suitable for connection of up to 4 transmitters with HART interface (multi-drop) - Pt-100 temperature sensor incorporating 4-wire technology, [EEx ib] IIC
MFE7	- 3 pulse or signal inputs (NAMUR), one of which alternatively for an ENCODER index or alternatively for frequency (densitometer) - Pulse integrity check acc. to ISO 6551 Level A - Serial RS485 interface. This interface is intended to connect an ultrasonic meter - 2 process inputs for sensors with 4 – 20 mA interface, alternatively suitable for connection of up to 4 transmitters with HART interface (multi-drop or burst mode) - Pt-100 temperature sensor incorporating 4-wire technology
Output boards	
MFA8	- 1 PhotoMos output (NC, max. 28.8 V, 120 mA) for alarm/message signalling - 3 PhotoMos outputs (NO, max. 28.8 V DC, 120 mA) for alarm/message or pulse output of up to 20 Hz - 4 0/4 - 20 mA analogue outputs for measurement readings
Communication boards	
ESER4	- 1 Ethernet connector (LAN) - 3 serial channels (RS232, RS485, RS422), baud rate up to 38.4 kB
Display	4.3 inch full-colour wide screen display with 480 x 272 pixels with LED backlight. Operation: touch screen display; 5 navigation keys and 2 special function keys; calibration switch
Power supply	24 V DC +/-20%, power consumption up to 12 W (typ. 5 W). Optionally: 230 V via external power supply
Temperature range	-20 °C to +50 °C
Dimensions / mounting	Plug-in unit in 19" design, 3 height units (3U), 1/3 or 1/2 width. Overall depth without plugs approx. 170 mm, with plugs approx. 220 mm. The 1/2 width version can take up to seven boards, the 1/3 width version up to four boards.
Approvals	MID European available Designed to comply with:PTB approval API chapter 21, OIML R117, NMI metrology requirement

For more information

To learn more about Honeywell Elster's Gas Solutions, visit www.honeywellprocess.com or contact your Honeywell account manager.

Honeywell Process Solutions

Germany

Elster GmbH

Steinern Str. 19-21

55252 Mainz-Kastel

T +49 6134 605 0

F +49 6134 605 223

www.elster-instromet.com

info@elster-instromet.com

Belgium

Elster NV/SA

Rijkmakerlaan 9

2910 Essen

T +32 3 670 0700

F +32 3 667 6940

www.elster-instromet.com

sales@elster-instromet.com

USA

Honeywell Process Solutions

Honeywell 1250 West Sam Houston Parkway

South Houston, TX 77042

www.honeywellprocess.com

Singapore

Elster-Instromet Sdn. Bhd. (Singapore Branch)

29 Tai Seng Avenue

#06-05A Natural Cool Lifestyle Hub

Singapore 534119

T +65 6247 7728

F +65 6848 9003

sales@elster-instromet.com.sg

Elster® is a registered trademark of Elster GmbH.
BR-xxxxxxx
© 2016 Honeywell International Inc.