

®ICP Accelerometer Model 101 Premium, Top connector

Main Characteristics

- Annular shear mode
- 10, 50, 100, 500 mV/g version available
- -55°C to 150 °C (-67°F to 302°F)
- Dual case isolation with Faraday shield
- Submersible version (150 metres) with associated IP68 overmolded cable
- life time hermetic sealing warranty (M12/Mil glass seal connector)

Competitive advantage

- Compare to obsolete compression design, annular shear piezoelectric sensors feature better frequency response, improved base strain, lower noise, smaller size, thermal transient immunity and insensitivity to cable motion. Annular shear mode is also less susceptible to transverse vibrations and better immune to electronic saturation at high frequency.
- 80 g dynamic range (thanks to exceptional bias stability) at elevated temperatures.
- Resistant to shock (magnet mounting) thanks to Jfet transistor input.
- ESD and reverse wiring protection.
- The glass seal hermetic connector protects the piezoelectric disc and the electronic from harmful environmental influences, significantly increasing their reliability and lifetime. Associated with low cost IP68 overmolded M12 cable assembly it is a perfect solution for submersible application down to 150 metres. Sensors with epoxy seal will always leak after few temperature cycles.
- M12 connector offers compatibility with numerous sensors used in automation. M12 overmolded cable assemblies are available from many cable manufacturers around the world. Mil cordset are expensive because they are only available from vibration sensor manufacturer.

Description

The hermetic sealed industrial piezoelectric accelerometer model 101 is design to monitor the vibration in harsh industrial environment. It uses the industry standard ©ICP / ©IEPE / ©LIVM 2-wire voltage transmission technique with a 4 mA standard constant current supply. Signal ground is isolated from the mounting surface and outer case to prevent ground loops. Faraday shielding will limit sensitivity to EMC to a minimum. Annular shear mode design will prevent from thermal transient and from spurious signal from high transverse vibrations. Low noise electronic and a temperature compensated design will give you accurate result over the complete temperature range. Large choice of frequency range will help to fit almost every customer requirements. Low frequency accelerometers (A=9) incorporate a low-pass filter within the conditioning electronic. This filter attenuates the sensor mechanical resonance and the associated distortion and overload.

Typical applications

Vibrations measurement in the rugged environments of industrial machinery monitoring. High frequency version monitor the vibration on roller bearing, pumps cavitation, Medium frequency version monitor overall vibration on pumps, motors, fans, ... Low frequency model is used in the petrochemical, machine tool, and paper industries for monitoring of slow speed agitators, cooling towers, ... High



Model 101.51-A-2 with overmolded IP 68 submersible M12 cable assembly

temperature version is typically used where extra temperature protection is needed, such as the dryer section of a paper machine.

Ordering information model 101

To order, specify model number, options, accessories and suffix :

101.51- AA - B - TT - MM - HH - YY

AA : Sensitivity

3 : 10 mV/g ± 5 % (high frequency)

3D : 10 mV/g ± 10 % (high frequency)

5 : 50 mV/g ± 5 % (high frequency)

5D : 50 mV/g ± 10 % (high frequency)

6 : 100 mV/g ± 5 % (medium frequency, general purpose)

6D : 100 mV/g ± 10 % (medium frequency, general purpose)

6Q : 100 mV/g ± 15 % (medium frequency, general purpose)

9 : 500 mV/g ± 5 % (low frequency)

9D : 500 mV/g ± 10 % (low frequency)

Available suffix : N, negative polarity

B : Connector

1 : MIL-C-5015, glass seal

2 : M12 glass seal

B(CC-DD) Integral cable

5 (CC-DD) : Integral cable

7 (CC-DD) : Integral cable with sstl overbraid protection

8 (CC-DD) : Integral cable with stainless steel protection conduit
5, 7, 8 : epoxy seal.

CC : Cable Type

01 : *Polyurethane twisted pair cable (90°C)

02 : *Teflon FEP twisted pair Cable (200°C)

03 : Radox twisted pair cable (120°C, halogen free)

DD : length in metre

TT : Temperature output.

omitted : no temperature output

T0 : 10 mV/°C. (range +2° to +120°C)

Not available with Mil-C-5015 2 pins connector

MM : Machine thread

omitted : no mounting stud will be shipped with the sensor.

M6 : M6x1

M7 : 1/4" 28 UNF 2A

M8 : M8x1.25

HH : Housing thread

H6 or omitted : M6x1 (China, Europe, India, South America, ...)
 H1 : M16x2 (quick mouting + 120° positioning) (Not stocked)
 H2 : Quick fit mounting (Not stocked)
 H7 : 1/4" 28 UNF-2A. (U.S.A., UK, ...)

YY : Agency Approval

omitted : no agency approval
 Y1 : Atex approved (July 2010)

Special Engraving :

Add ZXX at the end of the part number.
 XX is a number supplied by VibraSens

In stock Model

Metric connector
 101.51-6D-2-M6 100 mV/g ±10% general purpose version
 101.51-6-2-M6 100 mV/g ±5 % general purpose version
 101.51-9-2-M6 500mV/g ±5 % low frequency version
 101.51-3-2-M6 10 mV/g ±5 % high frequency version
 101.51-6D-2-T0-M6 100 mV/g ±10 % with temperature output
 American/UK connector
 101.51-6D-1-M7 100 mV/g±10 % general purpose
 101.51-6D-1-H7-M7 100 mV/g±10% (1/4"28UNF housing thread)
 101.11-6-1-M7 100mV/g±5 % high temp. version (150°C)
 101.51-9-1-M7 500mV/g±5 % low frequency version
 101.51-3-1-M7 10 mV/g 5 % high frequency version

Available Model with short lead time (1 week)

101.51-6D-5(01-Length)-M6 integral polyurethane cable
 101.51-6D-6(02-Length)-M6 integral 200°C sstl overbraided teflon cable

Old Part number compatibility

101.21-6 is replaced by 101.51-6D
 B=3 : M12 epoxy seal connector is obsolete. B=2 should be ordered.

Ordering example :

101.51-6D-2-M6 Premium accelerometer, 100mV/g, M12 glass seal connector
 101.51-6D-7(02-05)-M6 Premium accelerometer, 5 metres Integral teflon cable with Stainless steel overbraid.

Specifications (24°C)

Dynamic

Sensitivity (101.01)
 A=310 mV/g ±5%
 A=3D10 mV/g ±10%
 A=6100 mV/g ±5%
 A=6D100 mV/g ±10%
 A=6Q100 mV/g ±15%
 A=9500 mV/g ±5%
 A=9D500 mV/g ±10%
 Frequency response 101.01 & 101.51 (fig. 4a, 4b)
 A=3X ±10 % : 1 to 11000 Hz
 ±3 dB : 0.5 to 16000 Hz
 A=6X ±10 % : 1 to 9000 Hz
 ±3 dB : 0.5 to 14000 Hz
 A=9X ±10 % : 0.4 to 1600 Hz
 ±3 dB : 0.2 to 3700 Hz
 Mounted Resonant frequency
 A=3X35 kHz Nom
 A=6X25 kHz Nom
 A=9X16 kHz Nom
 Dynamic range
 A=3X500 g pk
 A=6X80 g pk
 A=9X10 g pk
 Transverse response sensitivity (20Hz, 5g)<5%
 Temperature responsefig3

Polarity(fig. 1) Suffix dependant
 Linearity ±1% Max
 Warm up time (Typical)
 A=3X, 6X < 1Sec
 A=9X < 10 Sec
 Option T0 (only available if sensor is powered)
 Output (between - and Temp)..... Vout=10mV/°C * Temp.(°C)
0VDC at 0°C
 Range +2° to 120°C

Electrical

Electrical Grounding Isolated from machine ground
 Internal Faraday shielding (fig. 1)
 Isolation(Case to shield) 100 MΩ Min
 Capacitance to ground 70 pF Nom
 Output impedance 50 Ω Nom
 DC output bias, 4mA supply 12 VDC Nom (Fig 2)
 Residual noise (24°C) : A=3X
 1 Hz to 25 kHz 300 ug rms
 1 Hz 30 ug
 Residual noise (24°C) : A=6X
 1 Hz to 25 kHz 300 ug rms
 1 Hz 30 ug
 Residual noise (24°C) : A=9X
 1 Hz to 25 kHz 25 ug rms
 1 Hz 2.4 ug
 Power requirements Constant current : +2 to +10mA DC
 Voltage : +22 to +28 VDC
 Protection : Overvoltage Yes
 : Reverse polarity Yes

Environmental

Temperature, operating continuous : 101.01 & 101.51 (max. current =4mA)
 A= 3X, 6X-55 to 120 °C (-65 to 250 °F)
 A=9X-55 to 90 °C (-65 to 212 °F)
 Temperature, operating continuous : 101.11 (max. current =4mA)
 A=6X, B=1-55 to 150°C (-65 to 302 °F)
 Humidity / Enclosure
 B=1, 2 Not affected, hermetically sealed, 1E-8storr./s
 B=5, 7, 8 IP68, epoxy sealed
 Acceleration limit : Shock5 000g peak
 : Continuous vibration500g peak
 Base strain sensitivity 0.0002 g pk/u strain
 Temp. transient sens. (3Hz, LLF, 20dB/dec)5 mg/°C
 Acoustic sensitivity (164 dBSP) 0.5 mg
 Electromagnetic sens. (50Hz, 0.03 T) 0.2 g
 Mean time between failure (MTBF) 10 Years Nom
 ESD Protection > 40 V
 Safety EN 61010-1 and IEC 1010-1
 EMC emission EN 50081-1, EN 50081-2
 EMC immunity (1) EN 50082-1, EN 50082-2

Physical

Dimensions
 B=1 Fig. 1a
 B=2 Fig. 1b
 B=5 Fig. 1d
 B=7 Fig. 1e
 B=8 Fig. 1f
 Design Ceramic, annular shear mode
 Weight with connector
 A=380 gr Nom (2.8 Oz)
 A=685 gr Nom (3.0 Oz)
 A=995 gr Nom (3.4 Oz)
 Connector
 B=1 MIL-C-5015 glass seal, Type MS3143 10SL-4P
 B=2 M12 glass seal, IEC 60947-5-2
 Material AISI 316L, DIN 1.4404 (Stainless steel)
 Housing thread Fig 1h
 Mounting torque (M6, M7, M8 suffix) 2.4 N.m (21 in-lbs)

Accessories, supplied

Calibration supplied
 Sensitivity (5g, 160 Hz)
 No frequency response

Accessories, not supplied

Cable assembly B=1 (Mil connector)
 Polyurethane cable 10.01-B22-A01-05-Length
 FEP Teflon cable 10.01-B22-A01-02-Length
 Cable assembly B=2 (M12 connector)

Polyurethane cable 10.01-E02-A01-31-Length
 FEP Teflon cable 10.01-E02-A01-02-Length
 For more cable option see Model 10.01 (specific cable harness).

Accessories, spares part

Mounting Stud with HH=H6

M6 machine thread..... 191.01-06-06-1
 1/4" 28 UNF machine thread 191.01-06-16-1
 M8 mahine thread 191.01-06-08-1

Standard Wiring color

With Mil-C-5015 cable assembly: + = Red // - = White // Temperature=black

With M12 cable harness: : + = Black // - = Blue // Temperature=White

Repair

Consult factory for replacement of connector in case of broken or bended pins. Repair of electronic is not possible.

(1) Guaranteed if using accessories listed in this product datasheet only

Drawings

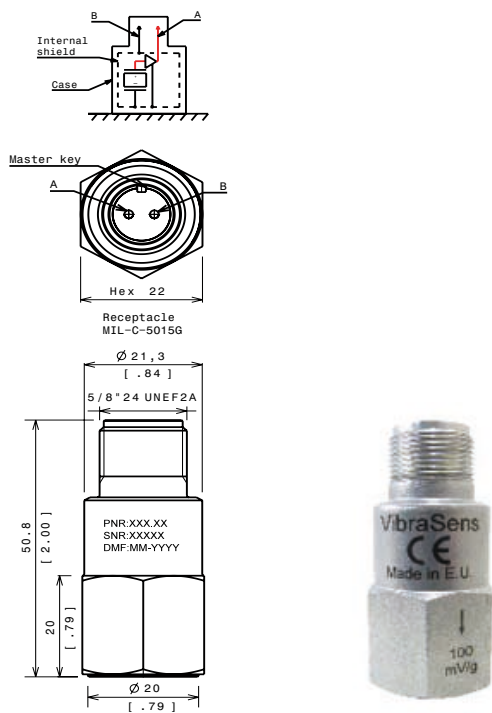

Model Number	Pin A	Pin B
Standard, no option	(+)	(-)
T0 Option (10mV/°C)	N/A	N/A

(N/A) : Not available

Fig 1a : Outline drawing & Electrical layout, B=1 (MIL-C-5015)

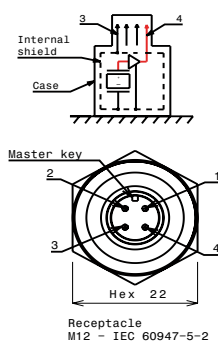

Model Number	Pin 1	Pin 2	Pin 3	Pin 4
Standard, no option	NC	NC	(-)	(+)
T0 Option (10mV/°C)	NC	(Temp)	(-)	(+)

(NC) : Not connected

fig 1b : Outline drawing & Electrical layout, B=2 (M12 glass seal)

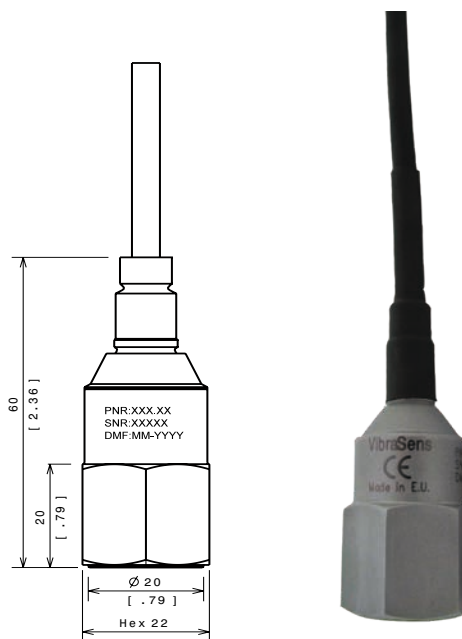

CC=01, 02 (PU, Teflon)	White (-) / Red (+)
CC=03 (Radox)	White N°1 (-) / White N°2 (+)
CC=12 (Teflon) (1)	White (-) / Red (+) / Black (Temp.)
CC=13 (Radox) (1)	White N°1 (-) / White N°2 (+) // White N°3 (Temp)
CC=31 (PU) (1)	Blue (-) / Black (+) / White (Temp.) / Brown (NC)

(1) T0 option (10mV/°C)

Fig 1d : Outline drawing & Electrical layout, B=5 (cable only)

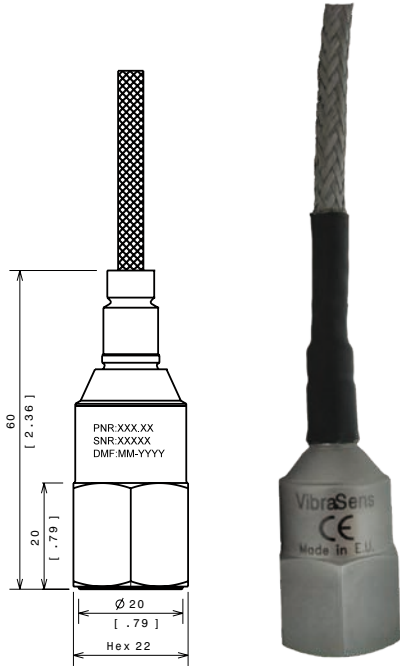

Fig 1e : Outline drawing B=7 (cable with overbraid)
electrical layout : See above B=5

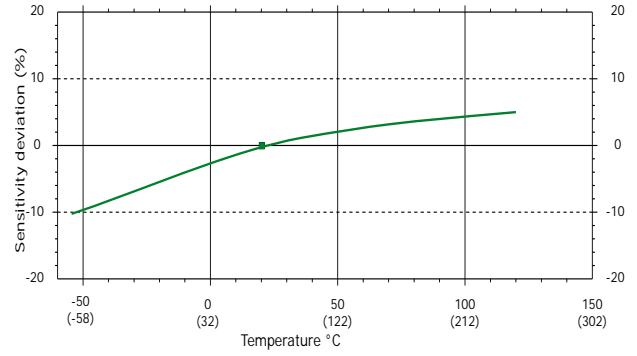

Fig 3 : Sensitivity deviation versus temperature

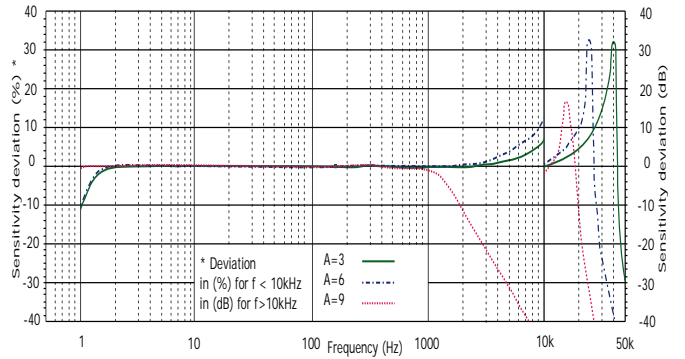

Fig 4a: Frequency response, amplitude

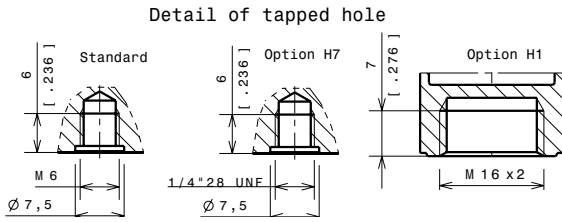

Fig 1h : Housing thread, option H1, H2, H7

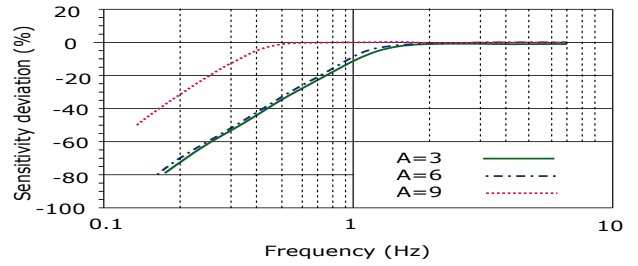

Fig 4b : Low Frequency response, amplitude

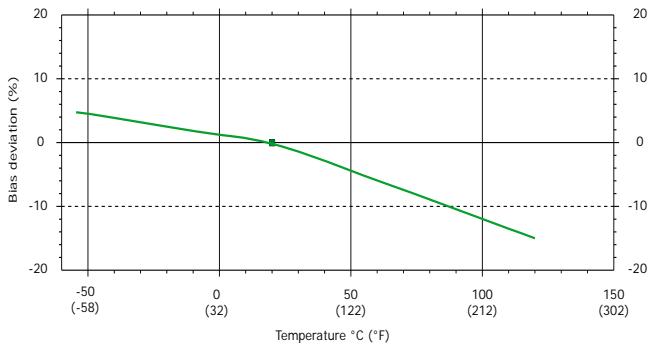

Fig 2 : DC (Bias) deviation versus temperature